

Light shift of coherent population trapping resonances

A. NAGEL, S. BRANDT, D. MESCHEDE and R. WYNANDS

*Institut für Angewandte Physik der Universität Bonn
Wegelerstr. 8, D-53115 Bonn, Germany*

(received 12 July 1999; accepted in final form 20 September 1999)

PACS. 42.50Hz – Strong-field excitation of optical transitions in quantum systems; multi-photon processes; dynamic Stark shift.

PACS. 32.70Jz – Line shapes, widths, and shifts.

PACS. 42.50Gy – Effects of atomic coherence on propagation, absorption, and amplification of light.

Abstract. – We have measured the spectral position of the absorption minimum in a coherent population trapping resonance in thermal cesium vapor as a function of light intensity. The dependence of position on intensity is found to be almost linear. We have furthermore studied the dependence of this light shift on neon buffer gas pressure and find a strong reduction for higher pressures. So the addition of a buffer gas not only reduces the linewidth of the resonance but also a very important systematic effect for precision measurements.

An atomic three-level system with two low-lying and long-lived levels (a so-called Λ system) can exhibit a two-photon resonance when the difference frequency of two driving fields matches the splitting of the two lower levels (fig. 1), $\omega_2 - \omega_1 = \omega_{12}$ [1]. The resonance is called “dark” since one-photon absorption and resonance fluorescence are strongly reduced because of the trapping of the atomic population in a coherent superposition state of the two lower levels that is no longer coupled to the light fields (coherent population trapping, CPT) [2]. The two-photon resonance can be very narrow [3, 4], with linewidths rivaling those of the microwave-driven magnetic dipole transition between the two lower atomic states. The use of dark resonances for the construction of atomic radio frequency standards [5] or applications for precision measurements, for instance in magnetometry [6], has been suggested, and first steps in this direction have been taken [7]. It is an essential requirement for such precision applications to understand the influence of experimental conditions on the position and shape of the resonance under investigation.

Because of the finite dephasing rate between the two lower states the position of the absorption minimum at the dark resonance can depend on intensity [8, 1], and in experiments a shift of the center of the resonance (light shift, AC Stark shift) is readily observed [9], as was discussed, for instance, for an atomic beam [5] or in connection with a CPT maser [10]. In this letter we report measurements of the light shift of the two-photon resonance that couples two hyperfine ground-state levels of the cesium atoms in a thermal vapor both with and without an additional buffer gas.

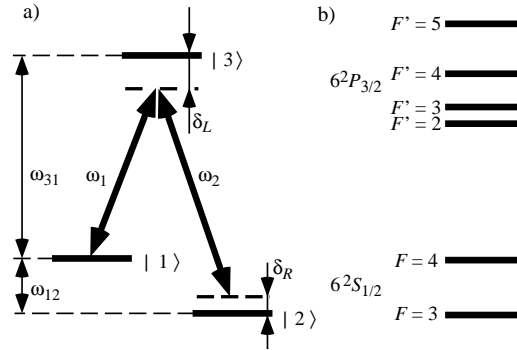

Fig. 1. – a) Important parameters in a three-level Λ system. ω_1, ω_2 denote the frequencies of the two laser fields. b) The actual situation on the D_2 line in cesium atoms.

The experimental setup [4] consists of two grating-tuned diode lasers ($\lambda = 852$ nm) that are electronically phase-locked to each other with a difference frequency of 9.2 GHz, corresponding to the cesium ground-state hyperfine splitting (fig. 2). The effect of the phase-locked loop is that the difference frequency and phase of the two laser fields are precisely determined by the stable and tunable 9.2 GHz frequency reference. In order to avoid Doppler broadening both laser beams have to be exactly parallel [3], and this is ensured by sending both laser beams through the same stretch of single-mode fiber. Behind the fiber the beam is collimated to a $1/e$ radius for the field of $r = 7.4$ mm before it passes through a cesium vapor cell (length 2 cm) at room temperature and is detected on a photo diode.

Laser frequency ω_1 is stabilized to the Doppler-broadened absorption profile in an auxiliary cesium vapor cell, at a frequency position near the crossover transition from the $F = 4$ ground state to the excited $F' = 3$ and $F' = 4$ levels. Therefore the one-photon detuning $\delta_L = \omega_1 - \omega_{31}$ remains constant. This operating point provides the most general case in the sense that both relevant velocity classes (see below) contribute with similar weight to the dark resonance line shape.

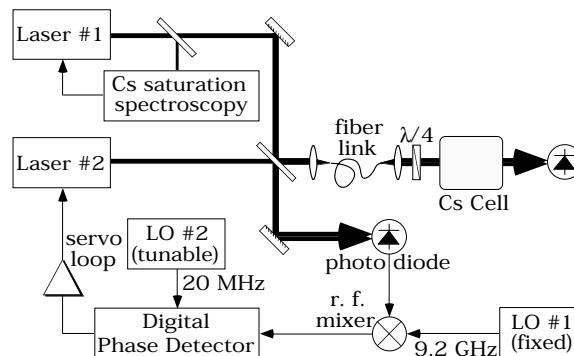

Fig. 2. – Experimental setup for the sensitive detection of intensity-dependent frequency shifts of the coherent population trapping resonance in cesium vapor. The sum of the two local oscillator (LO) frequencies determines the laser difference frequency via the phase-locking servo loop.

Laser frequency ω_2 is scanned through the dark resonance by detuning the 9.2 GHz oscillator, *i.e.*, δ_R . A longitudinal magnetic flux density of $24 \mu\text{T}$ was applied to the cell so that the dark resonance splits into seven components [11] because of the Zeeman structure of the cesium ground state. Only the dark resonance corresponding to the coupling of $|1\rangle = |6S_{1/2}, F = 4, m_F = 0\rangle$ and $|2\rangle = |6S_{1/2}, F = 3, m_F = 0\rangle$ was considered. This resonance is shifted by the magnetic field by only 50 Hz from the position at zero field.

The power P of laser 1 was varied from $5 \mu\text{W}$ to 1.1 mW which corresponds to effective intensities $I = 2P/\pi r^2$ from $6 \mu\text{W}/\text{cm}^2$ to $1.2 \text{ mW}/\text{cm}^2$ when the Gaussian beam profile is approximated by a top-hat distribution of radius $r/\sqrt{2}$ and the same height as the center of the Gaussian. The intensity of the other laser was always a factor of $2/3$ lower. These intensities correspond to the most interesting range for precision applications because for higher intensities the sensitivity is reduced by power broadening of the resonance [4]. In order to increase the signal-to-noise ratio the 9.2 GHz reference frequency was modulated with 1 kHz frequency and 1 kHz amplitude and the photo diode signal was demodulated with a dual-phase lock-in amplifier. The measured frequency modulation (FM) line shapes are a complicated superposition of the absorptive and the dispersive part of the resonance with non-negligible contributions by residual amplitude modulation caused by the phase-amplitude coupling inside the laser diode [12]. They are deconvoluted by a newly developed numerical algorithm [13] so that the true line shape and position of the dark resonance are revealed in a completely model-independent way.

The positions of the absorption minimum are plotted *vs.* effective intensity as circles in fig. 3. The intensity dependence appears basically linear, as one might have guessed by analogy to the behavior of a two-level system under monochromatic illumination. However, this shift is not simply given by the difference of the light shifts of the two individual optical transitions because of the reduced effective interaction strength near the dark resonance. With a slope of about $4 \text{ kHz}/(\text{mW}/\text{cm}^2)$ the light shift is an important systematic effect: at $1 \text{ mW}/\text{cm}^2$ a 1% intensity variation would amount to a line shift which is roughly equivalent to a magnetic flux density change of several tens of nT for a dark state magnetometer.

Close inspection of the low-intensity region (inset in fig. 3) reveals a small departure from a strictly linear behavior. While this effect hardly seems significant it is nevertheless visible in the curves for most buffer gas pressures (diamonds in fig. 3), so it is probably real. One can only speculate about its origin because a quantitative model for the multilevel system is not available. Let us give an intuitive picture of what might be causing the low-intensity structure, for simplicity for the case without buffer gas. Since the coherent dark state is populated by spontaneous emission from $F' = 3$ or $F' = 4$, there are two distinct velocity classes of width $\gamma c/\omega$ in the thermal vapor that contribute to the dark resonance (γ is the homogeneous optical linewidth). One of them consists of atoms with a velocity component v_3 along the laser beam such that they experience the lasers as being resonant with $F' = 3$. For the other class with velocity v_4 , the atoms are resonant with $F' = 4$. These contributions add incoherently to the observed signal because the hyperfine splitting of $F' = 3$ and $F' = 4$ is 202 MHz, much larger than $\gamma = 5.3 \text{ MHz}$, so that there is no overlap between the two velocity classes. Since in the experiment the lasers are tuned to the 3,4 crossover resonance both classes are offset to different sides of the Maxwellian velocity distribution. For the class v_3 this means that within the homogenous optical linewidth there are more atoms that see the laser slightly blue-detuned rather than red-detuned, and the other way round for class v_4 . Since the sign of the light shift depends on the sign of the detuning one expects a net shift in one direction for class v_3 and a shift in the other direction for class v_4 . Because of the different strengths of the transitions involved in the dark state preparation for v_3 and v_4 the two contributions have different weights, giving a sum curve with some complicated shape in general. It would

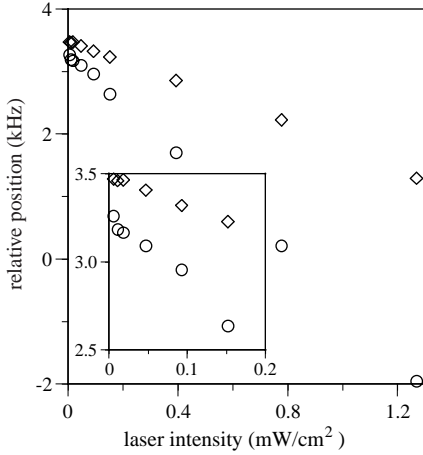

Fig. 3

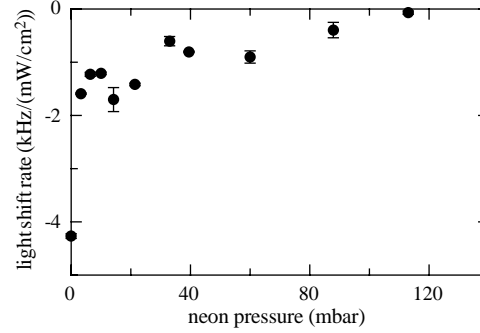

Fig. 4

Fig. 3. – Experimental points for the dark resonance position as a function of the intensity of the stronger laser. The inset enlarges the low-intensity region. Circles: no buffer gas; diamonds: 14 mbar neon added (for easier comparison this curve is downshifted by 7.5 kHz in order to compensate the pressure shift by the buffer gas [4]).

Fig. 4. – Light shift rate as a function of neon buffer gas pressure. The rate was approximated by the slope of a linear regression through the data points for intensities $I \geq 0.09$ mW/cm².

be surprising if its minimum traced out a linear curve as a function of intensity, so that some nonlinearity has to be expected.

How can this behavior be modeled correctly? Since 48 levels are involved in the cesium D_2 line transitions it is doubtful whether the physical insight gained from a complete numerical modeling of the realistic experimental situation is in appropriate proportion to the effort required. On the other hand, a mapping of the 48-level system onto a suitable 3-level system, whose susceptibility χ is easy to obtain completely analytically using today's computer algebra systems, is difficult because of optical pumping outside the Λ system under consideration (in general, the excited state can spontaneously decay into six ground-state levels of which only two are part of the Λ system). In a vapor cell the situation is complicated by the Maxwellian distribution $f_D(v)$ of atomic velocities v , causing a Doppler shift of the optical and the Raman detunings for the copropagating light fields. This tends to wash out the line shape asymmetry found for a stationary atom, where the asymmetry is strongest for large $|\delta_L|$, because the main contribution in the vapor stems from atoms near $\delta_L = 0$. However, a small net shift remains since for $\delta_L > 0$ ($\delta_L < 0$) with respect to a stationary atom there are more (less) atoms that see blue-detuned rather than red-detuned laser light. The situation is complicated even more because of the excited state hyperfine substates $F' = 2, 3, 4$, and 5. States $|6P_{3/2}, F' = 3, 4\rangle$ can both play the role of state $|3\rangle$ while states $F' = 2, 5$ contribute to a broadening of the resonance by allowing atoms to escape from the coherent superposition state via one-photon absorption [14].

There are several ways to reduce the effect of light shifts apart from an intensity stabilization of the lasers. For instance, one can choose a laser detuning δ_L such that the light shift vanishes [10]. Another way is to add a buffer gas which not only narrows the dark resonance line [4] but also broadens (by 8.6 MHz/mbar for cesium in neon [15]) the optical transitions. Since the influence of optical detuning should essentially depend on the ratio δ_L/γ , the shift

should be much smaller for a given detuning δ_L in a buffer gas than in an unbuffered vapor.

This is actually observed in the experiment. Using a refillable cesium vapor cell we have added neon at various pressures and measured light shift curves similar to the ones in fig. 3, where the curve for $p_{\text{Ne}} = 14$ mbar is also shown as an example. As a rough approximation, for each neon pressure a straight line was fitted through the data points for intensities $I \geq 0.09$ mW/cm², where the light shift curves are nicely linear. The slope of this line is plotted in fig. 4. The dramatic decrease in sensitivity to laser intensity fluctuations is readily apparent. For instance, at a pressure around 60 mbar, which is the pressure where the linewidth is smallest [4], the light shift rate is reduced by one order of magnitude as compared to the value of (-4.30 ± 0.06) kHz/(mW/cm²) in the unbuffered vapor.

In conclusion, we have measured the light shift of coherent population trapping resonances in thermal cesium vapor under D_2 line illumination and find an almost linear behavior. Addition of a buffer gas not only strongly reduces the linewidth but also the light shift, which is good news for envisioned precision applications.

We thank B. A. GRISHANIN and V. N. ZADKOV for valuable discussions on the theoretical aspects of the light shift in Λ systems. This work was supported by the Deutsche Forschungsgemeinschaft.

REFERENCES

- [1] ARIMONDO E., *Progr. Opt.*, **35** (1996) 257.
- [2] ALZETTA G., GOZZINI A., MOI L. and ORRIOLS G., *Nuovo Cimento B*, **36** (1976) 5.
- [3] AKULSHIN A. M., CELIKOV A. A. and VELICHANSKY V. L., *Opt. Commun.*, **84** (1991) 139.
- [4] BRANDT S., NAGEL A., WYNANDS R. and MESCHEDE D., *Phys. Rev. A*, **56** (1997) R1063.
- [5] HEMMER P. R., EZEKIEL S. and LEIBY C. C. jr., *Opt. Lett.*, **8** (1983) 440.
- [6] SCULLY M. O. and FLEISCHHAUER M., *Phys. Rev. Lett.*, **69** (1992) 1360.
- [7] NAGEL A., GRAF L., NAUMOV A., MARIOTTI E., BIANCALANA V., MESCHEDE D. and WYNANDS R., *Europhys. Lett.*, **44** (1998) 31.
- [8] COHEN-TANNOUJDI C., DUPONT-ROC J. and GRYNBERG G., *Atom-Photon Interactions* (Wiley, New York) (1992).
- [9] WYNANDS R., NAGEL A., GRAF L., BRANDT S., MESCHEDE D. and NAUMOV A., *International Quantum Electronics Conference (IQEC), Paper QWK2*, San Francisco, 1998.
- [10] VANIER J., GODONE A. and LEVI F., *Phys. Rev. A*, **58** (1998) 2345.
- [11] WYNANDS R., NAGEL A., BRANDT S., MESCHEDE D. and WEIS A., *Phys. Rev. A*, **58** (1998) 196.
- [12] LENTH W., *IEEE J. Quantum Electron.*, **20** (1984) 1045.
- [13] WYNANDS R. and NAGEL A., *J. Opt. Soc. Am. B*, **16** (1999) 1617.
- [14] NAGEL A., AFFOLDERBACH C., KNAPPE S. and WYNANDS R., *Influence of excited state hyperfine structure on ground state coherence*, to be published in *Phys. Rev. A*.
- [15] ALLARD N. and KIELKOPF J., *Rev. Mod. Phys.*, **54** (1982) 1103.